



Republic of the Philippines  
**METRO KIDAPAWAN WATER DISTRICT**  
 Lanao, Kidapawan City  
 Tel nos. (064) 577-1533, 577-1265, Fax # (064) 572-5555  
 E-mail Address: [metrokidapawan\\_wd@yahoo.com](mailto:metrokidapawan_wd@yahoo.com)  
 Website: [www.metrokidapawanwd.gov.ph](http://www.metrokidapawanwd.gov.ph)  
 "Committed to Service, Development and Self-Reliance"



**REQUEST FOR QUOTATION**

PR No. : 0821-007

DATE : \_\_\_\_\_

JO No. : \_\_\_\_\_

Name of Company: \_\_\_\_\_

Address: \_\_\_\_\_

Business Permit No: \_\_\_\_\_

TIN No.: \_\_\_\_\_

Please quote your best offer for the item/s described below, subject to the Terms and Conditions provided at the dorsal portion of this Request for Quotation. Submit your quotation duly signed by you or your duly authorized representative not later than \_\_\_\_\_, 2021.

\_\_\_\_\_  
 Procurement Assistant A

After having carefully read and accepted the Terms and Conditions below, I/we submit our quotation/s for the item/s as follows:

ITEM #	ITEM DESCRIPTION	Approved Budget of the Contract	OFFER					REMARKS	
			PRICE				Compliance with technical specifications		
			QTY.	UNIT	UNIT PRICE	TOTAL	YES		NO
1	COUPLING, COUPLING 150mm TYPE CI	PhP: <u>50,544.90</u>	6.00	pc			<input type="checkbox"/>	<input type="checkbox"/>	

GRAND TOTAL: \_\_\_\_\_

\_\_\_\_\_  
 Signature Over Printed Name:

\_\_\_\_\_  
 Contact Number (Landline/Cellphone)/Email Address

**TERMS AND CONDITIONS:**

- The mode of payment is within six (6) months.
- Bidders shall provide correct and accurate information required in this form.
- Bidders may quote for any at all times except for one (1) lot requisition.
- Price quotation/s must be valid for a period of thirty (30) calendar days from the date of submission.
- Price quotation/s, to be dominated in Philippine peso shall include all taxes, duties and/or levies payable.
- Quotations exceeding the Approved Budget for the Contract shall be rejected.
- Award of contract shall be made to the lowest quotation (for goods and infrastructure) or, the highest rated offer (consulting services) which complies with the minimum technical specifications and other terms.
- Any interlineations, erasures or overwriting shall be valid only if they are signed or initialed by you or any of your duly authorized representative/s.
- The item/s shall be delivered within ~~SEVEN~~ (7) days from receipt of Purchase Order/Job Order Contract, Notice of Award (NOA) and Notice to Proceed (NTP). The awardee shall notify two (2) days before its delivery of goods and services.
- The MKWD shall have the right to inspect and/or to test the goods to confirm their conformity to the technical specifications.
- Liquidated damages equivalent to one tenth of one percent (0.001%) of the value of the goods not delivered within the prescribed delivery period shall be imposed per day of delay. The MKWD shall rescind the contract once the cumulative amount of liquidated damages reaches ten percent (10%) of the amount of the contract, without prejudice to other courses of action and remedies open to it.



Republic of the Philippines  
**METRO KIDAPAWAN WATER DISTRICT**  
 Lanao, Kidapawan City  
 Tel nos. (064) 577-1533, 577-1865, Fax no. (064) 572-5555  
 E-mail Address: [metrokidapawan.wd@yahoo.com](mailto:metrokidapawan.wd@yahoo.com)  
 Website: [www.metrokidapawanwd.gov.ph](http://www.metrokidapawanwd.gov.ph)  
**"Committed to Service, Development and Self-Reliance"**



### TERMS OF REFERENCE

<b>PURPOSE</b>	<b>BATASAN ML REPAIR, MAK</b>		
<b>PARTICULARS</b>	<input checked="" type="checkbox"/> PR <input type="checkbox"/> JO No.:	<b>0821-007</b>	Date: July 30, 2021
<b>ITEMS, SPECIFICATIONS, AND DESCRIPTIONS</b>			
<b>ITEM 1 6 PCS - COUPLING SLEEVE TYPE CI 150mm Ø</b>			
<b>SPECIFICATIONS:</b>			
1 see attached annex a			
2			

*Note: For more than 6 items attach separate TOR Form. For More specifications attach necessary supporting documents.*

<b>SOURCE OF FUND</b>	<b>APP/PPMP Item No.:</b>	
	<b>Account No.:</b>	
<b>MODES AND TERMS OF PAYMENT</b>	Full payment within six months upon issuance of I.A.R	
<b>REQUIRED SERVICES</b>		
<input checked="" type="checkbox"/> Free Delivery	Others specify:	
<input type="checkbox"/> Free Product Demonstration		
<input type="checkbox"/> Free Installation		
<b>REQUIRED CERTIFICATIONS/ PERMITS</b>	None	
<b>QUALIFICATIONS</b>	Accredited supplier of Pipes & Fittings	
<b>AREA OF DELIVERY</b>	MKWD Manongol Reservoir Complex, Brgy. Manongol, Kidapawan City	
<b>DATE OF DELIVERY</b>	within 30 DAYS upon issuance of NOA/NTP	
<b>TIME OF DELIVERY</b>	9:00AM TO 4:00PM every weekdays	
<b>WARRANTY PERIOD</b>	POST INSPECTION WILL BE CONDUCTED AS REQUIREMENT FOR PAYMENT PREPARATION	
<b>RETENTION</b>	<b>Amount:</b>	n/a
	<b>Duration:</b>	n/a
<b>TAX INCLUSIVE</b>	Tax included in ABC	
<b>OTHER CONDITIONS AND CONSTRAINTS</b>		
Materials found to be defective and/or materials that are non-compliant to the standards or specification set upon delivery must be replace at the expense of the supplier.		
Prepared by:	Reviewed by:	
<b>KELVIN E. RUIBAN, CE</b> Acting Division Manager A-PDD	<b>RAMILA A. CONDEZ, CE, RM, MBA</b> Department Manager A - ECD	
Noted by:	Approved/Disapproved by:	
<b>WILESPER LISANDRO M. ALQUEZA, CE, RMP, MBA</b> AGM for Operations	<b>STELLA M. GONZALES, MPS</b> General Manager	



# ANNEX A

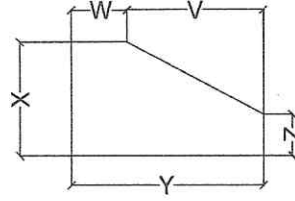
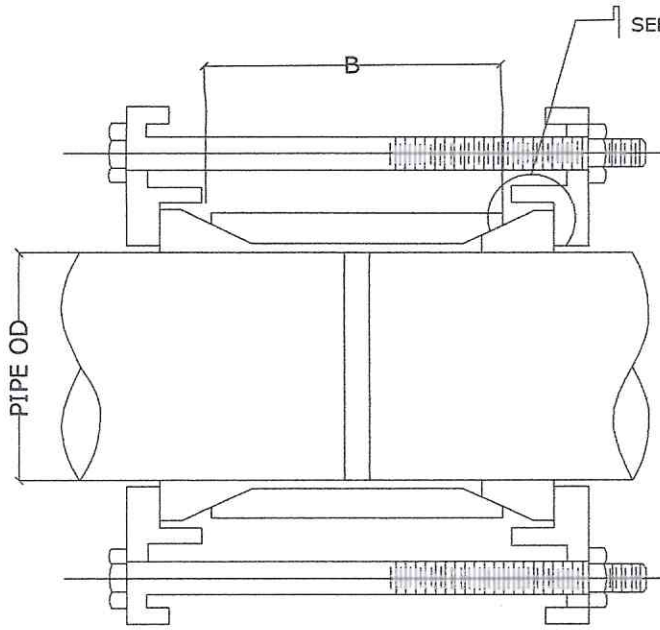

DIMENSION OF RUBBER GASKET

SIZE	V	W	X	Y	Z
50	15.75	7.87	12.20	23.6	3.8
75	15.75	7.87	12.20	23.6	3.8
100	19.05	7.87	15.75	26.9	5.6
150	19.05	7.87	15.75	26.9	5.6
200	19.05	7.87	15.75	26.9	5.6
250	19.05	7.87	15.75	26.9	5.6
300	19.05	7.87	15.75	26.9	5.6

C.I SLEEVE TYPE COUPLING FOR GIP

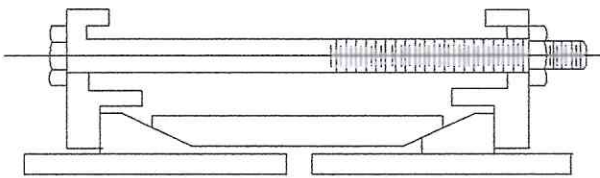

DETAIL "A"

SIZE	PIPE OD GIP	T	B	NO OF BOLT	E	T1	I
50	60.3	10	140	4	25	9.5	4.7
75	88.9	12	140	4	25	9.5	4.7
100	114.3	13	140	4	25	9.5	4.7
150	168.3	14	140	6	25	9.5	4.7
200	219.0	15.2	140	6	25	9.5	4.7
250	273.0	17.2	178	6	25	9.5	4.7
300	323.8	19	178	6	25	9.5	4.7

NOTES:

1. ALL DIMENSION ARE IN MILLIMETER
2. MATERIAL IS CAST IRON CONFORM TO ASTM A-126 CLASS B
3. MATERIAL OF BOLTS & NUTS IS STEEL CONFORM TO ASTM A-307 GRADE B. AND HOT DIP GALVANIZED AS PER ASTM A-153.
4. COATING: COALTAR ENAMEL
5. MATERIAL OF RUBBER GASKET CONFORM TO NBR